

# A dual hybrid forecasting model for support of decision making

*by* Purwanto Purwanto

---

**Submission date:** 28-Mar-2020 11:56PM (UTC+0700)

**Submission ID:** 1283971837

**File name:** dual\_hybrid\_forecasting\_model\_for\_support\_of\_decision\_making.pdf (1.04M)

**Word count:** 6342

**Character count:** 32288



Contents lists available at SciVerse ScienceDirect

## Advances in Engineering Software

journal homepage: [www.elsevier.com/locate/advensoft](http://www.elsevier.com/locate/advensoft)



# A dual hybrid forecasting model for support of decision making in healthcare management

Purwanto<sup>a,c,\*</sup>, Chikkannan Eswaran<sup>a</sup>, Rajasvaran Logeswaran<sup>b</sup>

<sup>a</sup>Faculty of Computing and Informatics, Multimedia University, 63100 Cyberjaya, Malaysia

<sup>b</sup>Faculty of Engineering, Multimedia University, 63100 Cyberjaya, Malaysia

<sup>c</sup>Faculty of Computer Science, Dian Nuswantoro University, 50131 Semarang, Indonesia

### 9 ARTICLE INFO

#### Article history:

Received 21 November 2011

Received in revised form 8 June 2012

Accepted 22 July 2012

Available online 19 August 2012

#### Keywords:

Dual hybrid forecasting models

Soft computing technology

Linear regression

Neural network

Fuzzy logic

Decision making

### A B S T R A C T

Forecasting of time series data such as fertility, morbidity and mortality rates is important for healthcare managers as these data serve as health indicators of a society. Accurate forecasting of these data based on past values helps the healthcare managers in taking appropriate decisions for avoiding possible calamity situations. Healthcare time series data consist of complex linear and nonlinear patterns and may be difficult to obtain high forecasting accuracy rates using only linear or neural network models. In this paper, we present a dual hybrid forecasting model based on soft computing technology. The proposed method makes use of a combination of linear regression, neural network and fuzzy models. The inputs to the fuzzy model are the forecast values of healthcare time series data. Based on a set of rules, the fuzzy model yields a qualitative output which is useful for decision making in healthcare management.

© 2012 Elsevier Ltd. All rights reserved.

## 1. Introduction

Many organizations conduct forecasting to anticipate changes in their environment. In practice, managers use the results of forecasting for strategic policy decisions. The forecaster provides predictive information of prediction for decision making with the goal of reducing the level of uncertainty in the future [1]. Forecasting is an integral part of the decision making activities. The need for forecasting increases in line with management efforts to reduce the dependence on situations which are uncertain [2].

Time series forecasting in healthcare such as fertility, morbidity and mortality rates is important for healthcare managers as these data serve as health indicators of a society. The forecasting of healthcare assumes importance for health departments since a good and accurate forecasting is very helpful in devising appropriate action plans. Healthcare data consist of complex linear and nonlinear patterns and it may be difficult to obtain high forecasting accuracy rates using only linear or neural network models. Accurate forecasting of these data based on past values helps the healthcare managers in taking appropriate decisions for avoiding possible calamity situations.

Time series forecasting has been employed in various applications to predict the future value using the past time series data. Statistical models such as weighted moving average, linear regression (LR) and autoregressive integrated moving average (ARIMA) have been used for prediction in various fields [3–6]. Soft computing techniques such as neural network models have been also used for forecasting in many applications [7–13]. LR models have limitations and they do not yield accurate prediction results [6], ARIMA models also have limitations to handle data with nonlinear patterns [7,12]. Though neural network models yield good results for nonlinear data, they are shown to yield mixed results for linear data [14].

The accuracy of prediction depends not only on the model but also on the characteristics of data. The prediction models proposed in [5] make use of fixed linear models for all types of data without considering the characteristics of the data. Similarly the neural network based prediction models reported in [13] do not optimize the network configuration based on the characteristics of data.

Forecasting models alone are not sufficient for decision making. In order to build a decision making system which gives the appropriate action plan based on the predicted data, the prediction model should be combined with fuzzy logic model. The rules used in the fuzzy logic model should be obtained from domain knowledge experts.

This paper focuses on dual hybrid model which can be used as a decision support system in healthcare applications. In dual hybrid model, we combine linear regression and neural network models

24  
\* Corresponding author at: Faculty of Computing and Informatics, Multimedia University, 63100 Cyberjaya, Malaysia.

E-mail addresses: [mypoenk@gmail.com](mailto:mypoenk@gmail.com) (P. Purwanto), [eswaran@mmu.edu.my](mailto:eswaran@mmu.edu.my) (C. Eswaran), [loges@mmu.edu.my](mailto:loges@mmu.edu.my) (R. Logeswaran).

1  
0965-9978/\$ - see front matter © 2012 Elsevier Ltd. All rights reserved.  
<http://dx.doi.org/10.1016/j.advensoft.2012.07.006>

to improve prediction accuracy and then based on the prediction results are applied to fuzzy logic to obtain a decision support system.

We propose a dual hybrid model for support of decision making. This model makes use of a hybrid model for forecasting and a fuzzy logic model for support of decision making. The inputs to the fuzzy model are the forecast values of three types of healthcare time series data, namely, mortality, morbidity and fertility. Based on a set of rules, the fuzzy model yields a qualitative output which is useful for decision making in healthcare management.

The healthcare data pertaining to the rates of mortality, morbidity and fertility are collected from sources such as Indonesian Health Profile (Ministry of Health Republic of Indonesia) and World Health Organization (WHO) for the period from 1995 to 2008. In the first stage, these data are input to the prediction model to obtain the expected rates for mortality, morbidity and fertility for the year 2009. In the second stage, we use fuzzy logic to obtain two types of criteria, namely 'good' or 'bad'. The determination of the type of criteria will be based on several fuzzy rules which are formulated by experts. The predicted rates for mortality, morbidity and fertility for the year 2009 which are the outputs of the prediction model in the first stage will form the basis for the formulation of the fuzzy rules. In third stage, we make use of a decision logic system to obtain appropriate action plan based on the output of the fuzzy logic system used in the second stage. The suggested actions from the decision logic system may include actions such as vaccination for couples, and pregnant women.

This paper is organized as follows. In the next section, we describe the related work. Section 3 presents the concepts of linear regression, neural network, hybrid and the various measures used for performance evaluation. Section 4 describes the methodology of the proposed dual hybrid model. Section 5 describes the empirical evaluation. In this section, the experiment results obtained by using the proposed dual hybrid forecasting model for the healthcare data are presented. Section 6 contains the concluding remarks.

## 2. Related work

Zhar [4] has reported that statistical models such as ARIMA models are not efficient in handling data with nonlinear patterns. On the other hand, it has been reported many researchers that though neural network models can handle nonlinear data efficiently, it yields mixed results in handling data with linear patterns [12,14].

Support vector machine (SVM) models have been also used for prediction in many applications. The SVM models have advantages such as existence of a global optimal solution, elimination of over-training, efficient calculation of nonlinear solutions [15]. Besides the advantages, the SVM models also have disadvantages, such as higher computation time to obtain optimum parameter values compared to ARMA model and difficulty in applying for large scale problems [16,17].

Thissen et al. [15] have reported that the ARMA model performs better for simulated ARMA data set compared to SVM model and for real-world dataset both ARMA and SVM models yield similar results. In [18], it is reported that the prediction accuracy of the LS-SVM model is similar to that of ANN model for quantum chemistry data. For the prediction of virological response to combination of HIV therapy and for the prediction of financial time series data, the performance of SVM model was found to be superior to that of ANN model. [19,20]. On the other hand, the ANN model was found to be superior compared the SVM model for defect prediction in hot strip rolling [21]. Based on these results, we can conclude that the performances of these models vary depending on the type of data.

In the real-world, time series data are often very complex comprising both linear and nonlinear patterns. It is difficult to obtain high prediction accuracy by using only statistical or neural network models. Hybrid models that combine both statistical and neural network models can be expected to improve the forecasting accuracy rates. The hybrid models have been used for univariate time series prediction in many applications and it was found that the hybrid model yield more accurate prediction results compared to individual models [14,21–23].

Neuro-fuzzy models have been used in various applications such as forecasting of water level in reservoir, weather forecasting, WIMAX traffic forecasting and stock market forecasting [24–26]. Woodside et al. have used neuro-fuzzy model for healthcare claim payment processing [27]. Neuro-fuzzy model has also been used in other healthcare applications such as prediction of psychosomatic disorders [28], modeling of breast cancer survival [29], and medical application [30].

Several methods based on fuzzy logic have been reported for applications such as demand forecasting and medical decision making [31,32]. A combination of stochastic dynamic model and fuzzy logic has been used to determine the degree of severity of event [33].

## 3. Time series forecasting models

It is known that the data arising out of many phenomena are nonlinear in nature. In other words, there exist nonlinear relationship between the past and the present data. In such situations, the linear time series forecasting models are inadequate and as a consequence nonlinear time series models such as neural networks have received great deal of attention in the last few years. In healthcare, the time series data consist of complex linear and nonlinear patterns. It may be difficult to obtain high prediction accuracy rates using only linear or only neural network models. Hence, hybrid models which combine both linear and neural network models can be used to obtain high prediction accuracy rates.

### 3.1. Linear regression model

Linear regression model is a statistical technique that has been applied in various fields. The model is one of the most commonly used methods for forecasting [34,35]. The regression model describes the mean of the normally distributed dependent variable  $y$  as a function of the predictor or independent variable  $x$  [34]:

$$y_t = \beta_0 + \beta_1 x_t + \varepsilon_t \quad (1)$$

where  $y_t$  is the value of the response or dependent variable from the  $t$ th pair,  $\beta_0$  and  $\beta_1$  are the two unknown parameters,  $x_t$  is the value of the independent variable from the  $t$ th pair, and  $\varepsilon_t$  is a random error term.

The estimated values of the regression model are calculated as [35]:

$$\hat{y}_t = b_0 + b_1 x_t \quad (2)$$

where  $b_0$  is the intercept and  $b_1$  is slope parameter.

### 3.2. Neural network model

There are many nonlinear models that can be used for forecasting. One of the models is neural network model. The motivation using neural network for forecasting is based on the fact that the model has capable in handling the nonlinear relationships among the data [36]. Neural network models have had considerable success in the nonlinear domains. The output value of a multilayer back propagation neural network is computed as [36]:

$$Y(x) = \beta_0 + \sum_{j=1}^H \beta_j \psi \left( \gamma_{j0} + \sum_{i=1}^n \gamma_{ji} x_i \right) \quad (3)$$

where  $(\beta_0, \beta_1, \dots, \beta_H, \gamma_{10}, \dots, \gamma_{Hn})$  are the weights or parameters of the neural network. The non-linearity enters into the function  $Y(x)$  through the so called activation function  $\psi$ .

The activation functions  $\psi$  used in this paper is a hyperbolic tangent function which is defined as [37]:

$$\psi(x) = \tan h(x) = \frac{e^x - e^{-x}}{e^x + e^{-x}} \quad (4)$$

### 3.3. Hybrid model for forecasting

In the real problem, the time series data consist of complex linear and nonlinear patterns. The accuracy rates obtained using linear models may not be high as they have limitations in handling the nonlinear relationships among the data. Neural network models are considered to be better in handling such nonlinear relationships.

In general, the time series data is composed of a linear autocorrelation structure and a nonlinear component, given by [14]:

$$v_t = L_t + N_t \quad (5)$$

where  $L_t$  and  $N_t$  represent the linear and nonlinear components respectively.

In this paper, we use linear regression as the linear model to predict the linear component  $\hat{L}_t$ . The residual or error series  $e_t$ , obtained from the linear model contains information on the non-linearity of the series, given by:

$$e_t = y_t - \hat{L}_t \quad (6)$$

$e_t$  is then applied to a neural network model to obtain the predicted output  $\hat{N}_t$ , which is combined with  $\hat{L}_t$  to get the overall prediction of the hybrid model, given by [14]:

$$\hat{y}_t = \hat{L}_t + \hat{N}_t \quad (7)$$

where  $\hat{y}_t$  represents the combined forecast value of the hybrid model at time  $t$ .

### 3.4. Performance measures

The prediction or forecasting models are evaluated in terms of their ability to forecast the future values. Several measures are used in comparing the forecasting performances of different models in this study, namely Root Mean Square Error (RMSE) and mean absolute error (MAE).

The MAE measure is computed as follows [38]:

$$MAE = \frac{\sum_{t=1}^n |Y_t - \hat{Y}_t|}{n} \quad (8)$$

The RMSE is computed as follows [38,39]:

$$RMSE = \sqrt{\frac{\sum_{t=1}^n (Y_t - \hat{Y}_t)^2}{n}} \quad (9)$$

## 4. Proposed dual hybrid methodology

The dual hybrid methodology proposed in the work consists of four steps as shown in Fig. 1.

$$\mu_{Medium}(mortality) = \begin{cases} \frac{(mortality-27)}{42-27} & 27 < mortality \leq 42 \\ \frac{57-mortality}{57-42} & 42 < mortality \leq 57 \\ 0 & otherwise \end{cases}$$

The steps of dual hybrid methodology are described as follows:

**Step 1.** The time series data such as mortality, morbidity and fertility from healthcare are retrieved from the healthcare database. In this step, we will check all datasets to find whether there is any missing and outlier values. Any missing value in the data set is replaced with the average value of the variable concerned. And to test whether any data in the data set is an outlier, we use the standardized score  $Z_x$  is calculated as:

$$Z_x = \frac{x - \bar{x}}{S_x} \quad (10)$$

where  $x$  is the value of variable,  $\bar{x}$  is the mean of  $x$  and  $S_x$  is the standard deviation of  $x$ .

The data value is considered as an outlier if  $Z_x > +2.5$  or  $Z_x < -2.5$  with 5% significance level (95% confidence level). If the dataset has outliers, the outlier data will be removed.

**Step 2.** A hybrid model is used for time series forecasting in healthcare. We use the hybrid model which combines LR and neural network models. LR model is used to predict the linear component and the residuals are applied to a neural network model to obtain the predicted the nonlinear component. The combination of both these models characterizes the hybrid model denoted as LRNN model (Linear Regression and Neural Network). The hybrid model is used for time series prediction using mortality, morbidity and fertility datasets. The prediction results of these three variables are stored in memory and then they are used as inputs to the fuzzy logic model.

**Step 3.** Fuzzy logic contributes to decision making. The fuzzy model makes use of the predicted time series data pertaining to three types of healthcare time series data, namely, mortality, morbidity and fertility. The Fuzzy system is designed using a set of rules with the Mamdani approach. The processes involved in the design are follows:

### 4.1. Fuzzification

Fuzzification of the input and output variables is performed by considering convenient linguistic subsets using membership functions. This phase takes the crisp inputs and determines the degree to which these inputs belong to each appropriate fuzzy set.

Fuzzy healthcare data, such as mortality, morbidity and fertility can be defined using fuzzy concepts. In this case, the input variables (mortality, morbidity and fertility) are categorized into three fuzzy sets, namely, "High", "Medium" and "Low". Each variable is grouped into one of these fuzzy sets based on the membership function.

The Linguistic values are assigned for each input as "Low", "Medium" and "High" while the two possible values for the output criteria variable are termed as: "Bad" and "Good". The linguistic variables and their ranges are shown in Table 1. For mortality variable, the range of universe of discourse is [0–70], which means that the minimum and maximum values of mortality are equal to 0 and 70 respectively. The Domain term used in column 5 of Table 1 contains the parameter values corresponding to L function and triangular fuzzy number used for defining the fuzzy sets. For the three input variables, L function is used for "Low" and "High" fuzzy sets and triangular fuzzy number is used for "Medium" fuzzy set [40]. For example, the membership function for the input variable mortality is defined as follows:

$$\mu_{Low}(mortality) = \begin{cases} 1 & mortality \leq 16 \\ \frac{42 - mortality}{42 - 16} & 16 < mortality \leq 42 \\ 0 & mortality > 42 \end{cases}$$

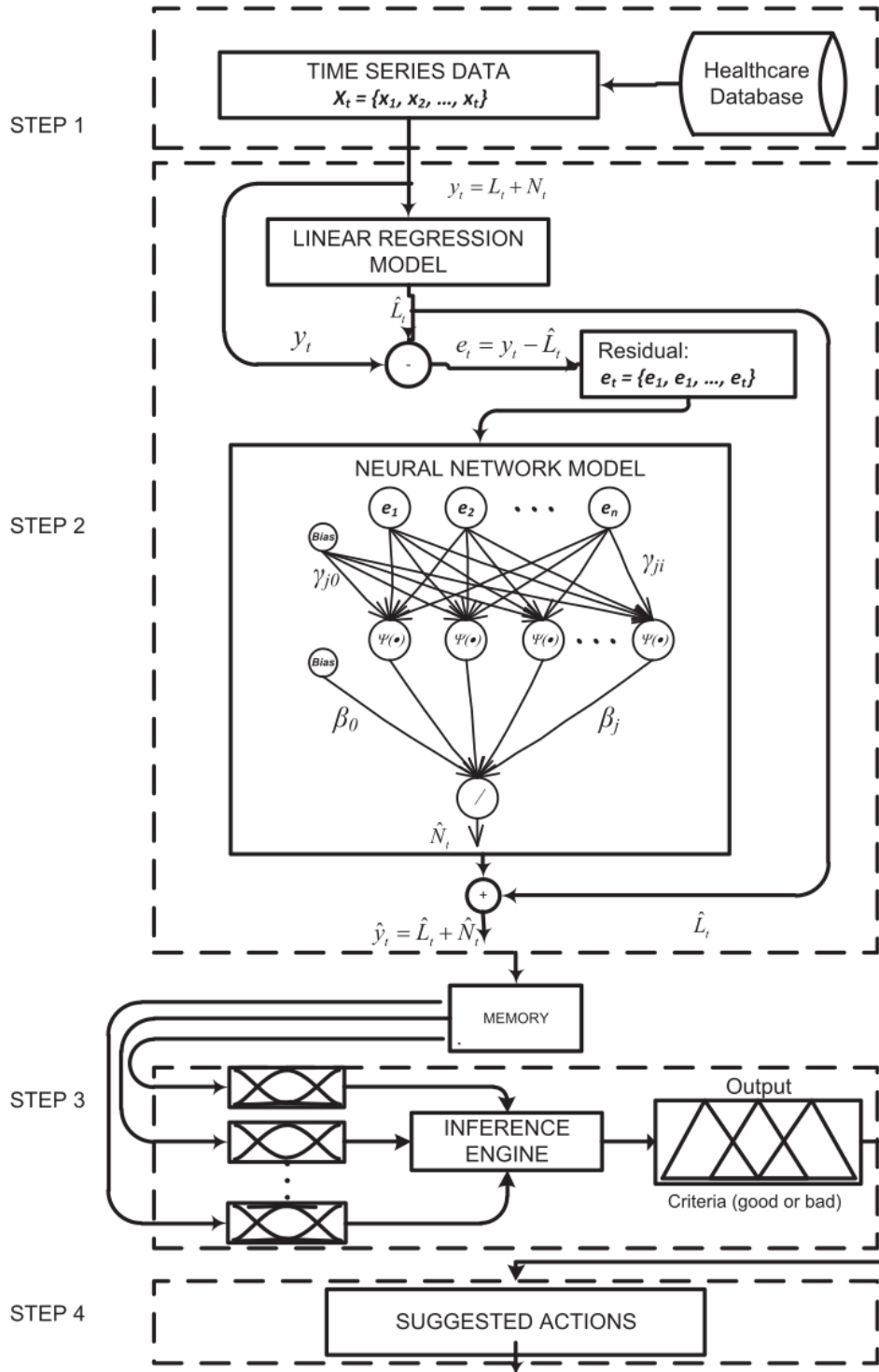

Fig. 1. The methodology of dual hybrid model.

$$\mu_{High}(mortality) = \begin{cases} 0 & mortality \leq 42 \\ \frac{68 - mortality}{68 - 42} & 42 < mortality \leq 68 \\ 1 & mortality > 68 \end{cases}$$

It is to be noted that the values of parameters in *L* function and triangular fuzzy number are determined by expert's knowledge. For the output variable "criteria", the range of universe of discourse is [0–100]. The membership function for "criteria" is determined as follows:

$$\mu_{Bad}(criteria) = \begin{cases} 0 & criteria \leq 10 \\ \frac{60 - criteria}{60 - 10} & 10 < criteria \leq 60 \\ 1 & criteria > 60 \end{cases}$$

$$\mu_{Good}(criteria) = \begin{cases} 0 & criteria \leq 40 \\ \frac{90 - criteria}{90 - 40} & 40 < criteria \leq 90 \\ 1 & criteria > 90 \end{cases}$$

4.2. Construction of fuzzy IF-THEN rules

In this phase, we construct fuzzy IF-THEN rules based on the expert knowledge in order to model the problem. The fuzzified inputs are constructed to the antecedents of the fuzzy IF-THEN rules. The fuzzy "AND" operation is used to evaluate the conjunction of the rule antecedents. In this work, we have formulated 27 fuzzy

IF-THEN rules which were derived by mapping the three inputs to one output by using the fuzzy "AND" operation. The construction of the fuzzy rules with all the possible permutations of rules based on the three antecedents, Low (L), Medium (M) and High (H), and the two criteria Bad (B) and Good (G), are shown in Fig. 2. Some examples of fuzzy rules are given below:

- (a) If Mortality is Low AND Morbidity is Low AND Fertility is High then Criteria is Bad.
- (b) If Mortality is Low AND Morbidity is Medium AND Fertility is High then Criteria is Bad.
- (c) If Mortality is Medium AND Morbidity is Low AND Fertility is Low then Criteria is Good.

4.3. Aggregation of the rule outputs

In this phase, we take the membership functions of 27 rules consequents previously scaled and combine them into a single fuzzy set.

4.4. Defuzzification

The resulting fuzzy set requires defuzzification to arrive at a crisp value for final use. The input for the defuzzification process is the aggregated output fuzzy set and the output is a number. This step was performed using the gravity center technique [26]. The crisp output of the inference engine in the fuzzy model is used in the criteria curve to obtain the type of fuzzy criterion, namely, "Good" or "Bad". This will be the final output from stage 3 in Fig. 1. For example, if the values for mortality, morbidity and

Table 1 Linguistic variables and ranges.

Function	Variable	Fuzzy	Universe of discourse	Domain
Input	Mortality	Low	[0-70]	[001642]
		Medium		[274257]
		High		[42687070]
	Morbidity	Low	[0-500]	[00166308]
		Medium		[225308390]
		High		[308448500500]
	Fertility	Low	[0-40]	[001721]
		Medium		[172126]
		High		[21264040]
Output	Criteria		[0-100]	[001060]
				[4090100100]

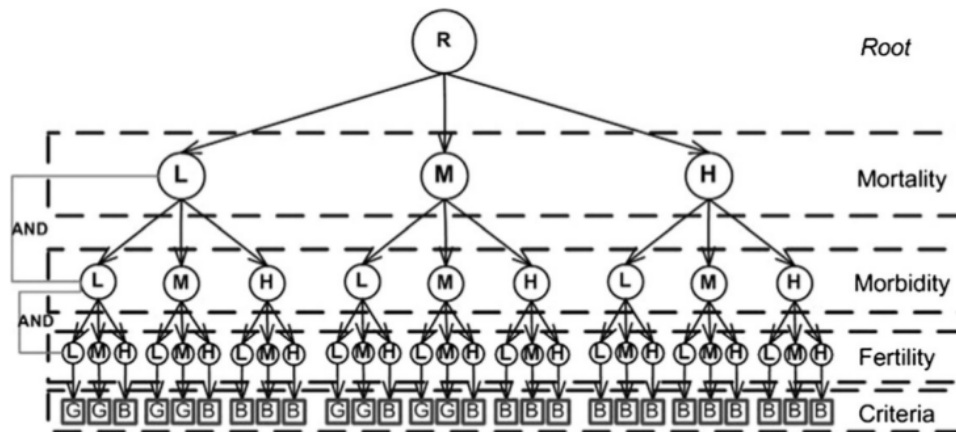

Fig. 2. The construction fuzzy rules.

**Table 2**  
Descriptive statistics of IMR, CBR and MTB data in Indonesia (1995–2008).

Data	Min	Max	Mean	Std. dev.	Variance
CBR	19.24	24.06	21.85	1.53	2.34
MTB	244.20	380.10	307.07	46.91	2200.90
IMR	31.00	55.00	42.43	8.72	76.11

**Table 3**  
Prediction of IMR, MTB and CBR using Hybrid Model for 2001–2009.

Year	Mortality (IMR)		Morbidity (MTB)		Fertility (CBR)	
	Actual	Prediction	Actual	Prediction	Actual	Prediction
2001	50	49.20	314.00	314.16	22.26	22.26
2002	35	35.09	297.10	297.33	21.87	21.87
2003	38	37.93	286.70	286.31	21.49	21.49
2004	36	36.21	274.20	273.83	20.71	20.71
2005	36	36.07	260.90	260.76	20.71	20.71
2006	34	34.13	250.70	251.15	20.34	20.34
2007	32	32.03	244.20	244.42	19.65	19.66
2008	31	31.09	253.00	252.63	19.24	19.24
2009		29.18		243.23		19.11
MAE		0.1868		0.2918		0.0032
RMSE		0.3008		0.3121		0.0037

**Table 4**  
Comparison of performance measures for prediction models.

No.	Model	IMR		MTB		CBR	
		MAE	RMSE	MAE	RMSE	MAE	RMSE
1	Linear regression	1.858	2.767	4.079	6.488	0.239	0.338
2	ARIMA	2.183	3.375	3.414	5.255	0.138	0.195
3	Neural network	0.247	0.312	0.853	1.112	0.137	0.168
4	Hybrid (LR + NN(6,10,1))	0.1878	0.3008	0.2918	0.3121	0.0032	0.0037

fertility are 261, 36.1, 20.7 respectively, the crisp output of the fuzzy inference engine will be 75.3 as shown in Fig. 5. Referring to the criteria curve shown in Fig. 4d, we get the fuzzy criterion 'Good' corresponding to a value of 75.3

Step 4. Finally, based on the output of the FIS (i.e. criteria is 'Good' or 'Bad'), appropriate action plans are suggested for health-care management.

## 5. Empirical evaluation

### 5.1. Subject data

The healthcare data pertaining to Indonesia for the period 1995–2008 such as infant mortality rate (IMR), morbidity of tuberculosis (MTB) and crude birth rate/fertility (CBR) which are used in this study were collected from the Indonesian Health Profile (Ministry of Health Republic of Indonesia), World Health Organization (WHO) [41–43].

The descriptive statistics of the CBR, MTB and IMR data such as the minimum, maximum, mean, standard deviation and variance are shown in Table 2.

It is noted that the time series healthcare data are first processed to check for the missing values and outliers.

### 5.2. Results and discussion

In this section, we present the experiment results obtained by using the proposed dual hybrid model for the healthcare data. The results of forecasting such as mortality, morbidity and fertility are used as input to the fuzzy logic to determine the recommended actions.

In the next step, we compute time series forecasting using the hybrid model which is a combination of linear regression and neural network models. Architecture configurations with different numbers of input and hidden layer neurons were tested to determine the optimum setup. Similarly, different activation functions such as hyperbolic tangent, bipolar sigmoid and sigmoid functions were tested. From the experimental results, it is found that the

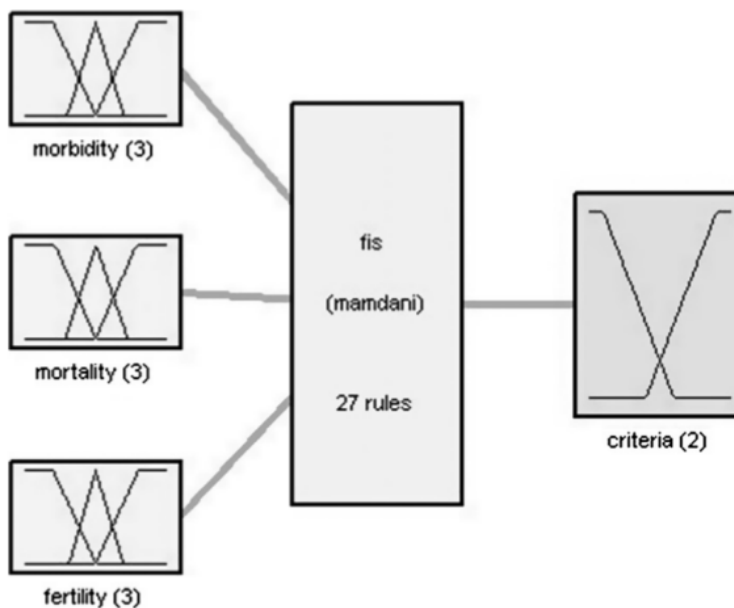

Fig. 3. Fuzzy inference system for criteria.

neural network model with 6 input neurons, 10 hidden layer neurons and using hyperbolic tangent activation functions for the hidden and output layers yields the best results.

The results of the time series prediction of IMR, MTB and CBR using the hybrid model, which is a combination of linear regression and optimum neural network model is shown in Table 3. From the table, it is noted that the predicted values obtained are very close to the actual values for actual healthcare data (IMR, MTB and CBR) during the test period of 2001–2008. The mean absolute error (MAE) values obtained using mortality, morbidity and fertility data are 0.1868, 0.2918 and 0.0032, respectively. These are a fraction of the actual values (less than 1%), proving that the proposed hybrid system performed well. The best results were obtained for the Fertility (CBR) data, where the error measures were less than 0.02% of the actual values.

To evaluate the performance in relation to the linear only and neural network only models, the performance of these models on the test data were evaluated.

Table 4 shows a comparison of MAE and RMSE values obtained using linear regression, neural network, ARIMA and hybrid models. It is seen from Table 4, that the smallest values of MAE and RMSE for all variables were obtained by the hybrid model. Hence, it could be concluded that the hybrid model combining linear regression and neural network is the best model for mortality (IMR), morbidity of tuberculosis (MTB) and fertility (CBR) data. For the IMR data, the improvement of MAE achieved by the hybrid model over the LR

model was 1.671 (89.95%) and 0.0601 (3.24%) over the neural network model. For MTB, the value of MAE achieved by the hybrid model improved by 3.7876 (92.85%) and 0.5611 (13.75%) over the LR and neural network models, respectively. For CBR, the MAE improvement was 0.2356 (98.66%) and 0.1341 (56.16%) over LR and neural network models, respectively. Thus, it is clear that the proposed hybrid model is able to achieve significant performance improvement over the individual models such as linear regression, ARIMA and neural network models.

Fig. 3 shows the Fuzzy Inference System (FIS) constructed with the three input variables: morbidity, mortality and fertility with 27 rules. The output variable is 'criteria'. In this case, the chosen model is Mamdani [44].

The plots of the membership functions of mortality, morbidity, fertility and criteria are given in Fig. 4.

In Fig. 1, we see that the output of the fuzzy model is generated by combining the three forecast values resulting from the hybrid model. The number of rules equals all possible permutations of categorized system inputs. 27 fuzzy IF-THEN rules were constructed for this system.

Fig. 5 shows the fuzzy reasoning using 27 rules with multiple antecedents. The first column represents morbidity variable, second column represents mortality variable and the third column represents fertility variable and the last column represents the criteria variable. The morbidity, mortality and fertility variables are the inputs to the inference engine (see Fig. 5) and the crisp value

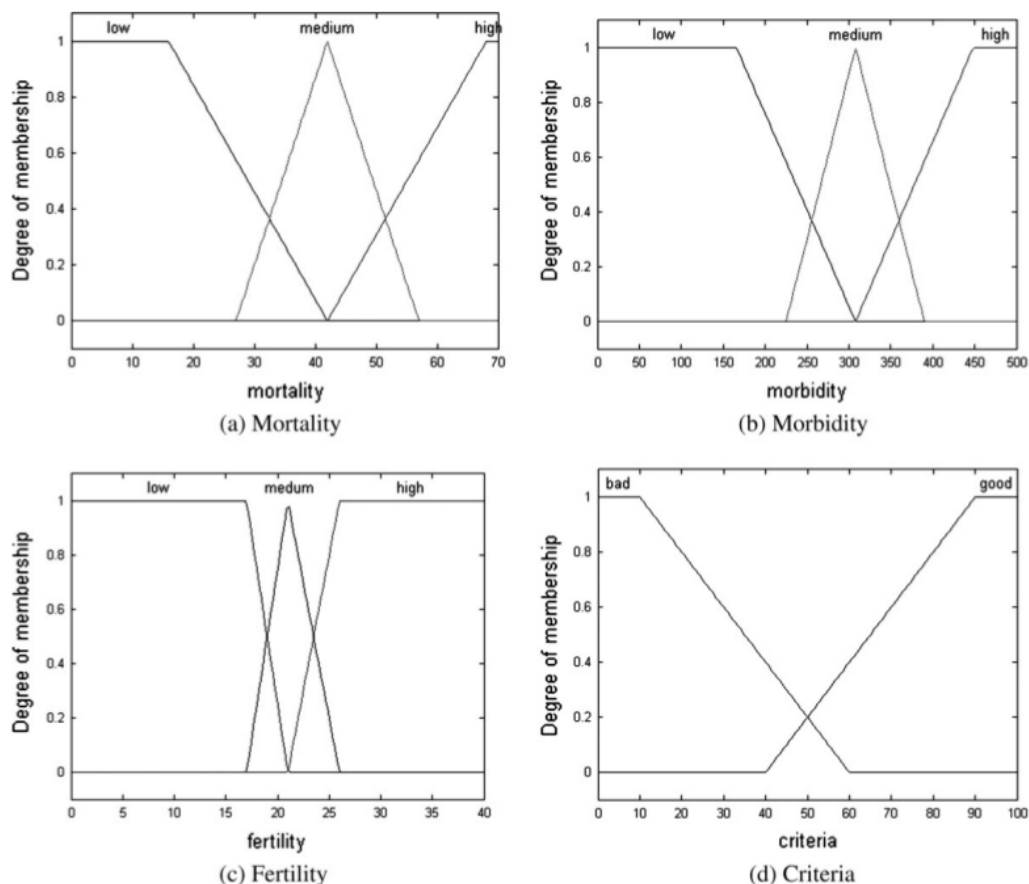

Fig. 4. The membership function plot of input and output.



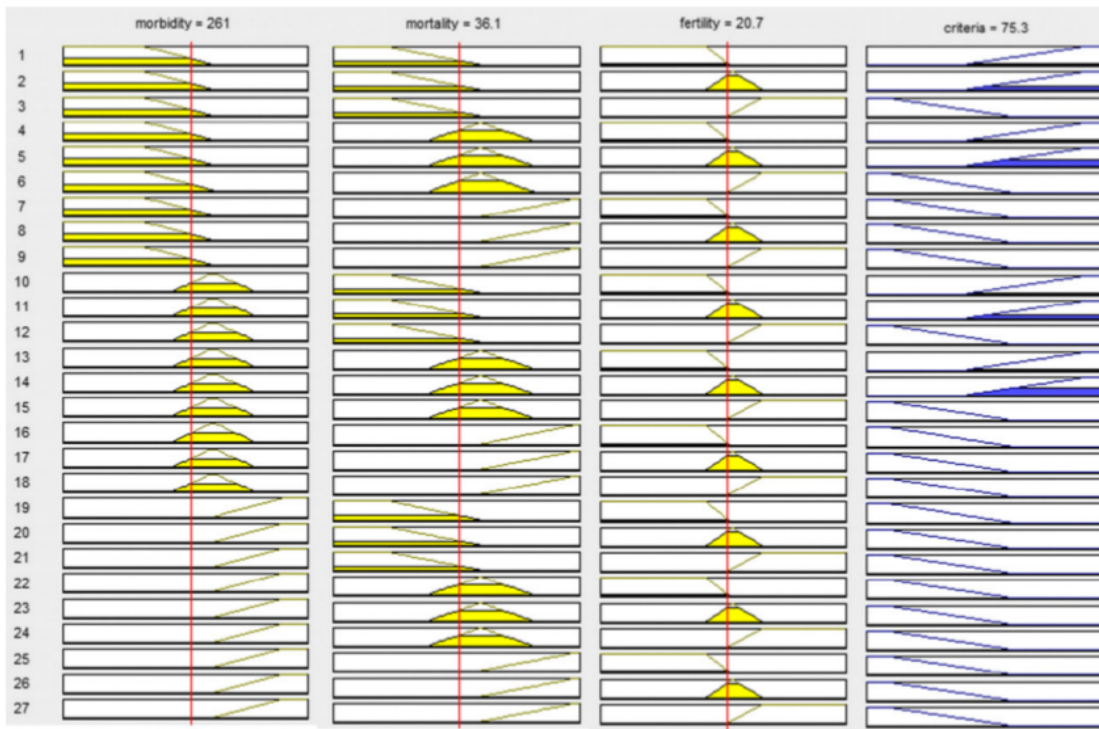

Fig. 5. The fuzzy reasoning.

**Table 5**  
Result of the Criteria-Level and Implication for 2005–2009.

Year	Input			Output	
	Mortality	Morbidity-TB	Fertility-CBR	Criteria-level	Implication
2005	36.07	260.76	20.71	75.3	Good
2006	34.13	251.15	20.34	74.9	Good
2007	32.03	244.42	19.66	74.7	Good
2008	31.09	252.63	19.24	74.8	Good
2009	29.18	243.23	19.11	75.5	Good

calculated using gravity center technique will be the output of the inference engine. In Fig. 5, the shapes of the membership function of the rules are shown graphically in terms of “L” and triangular functions for Low, Medium and High for each of the input variables. The criteria variable is the minimum value of the three input variables after the AND operation is performed on the input variables corresponding to each rule. All the plots of the criteria variables corresponding to the 27 rules are combined to get a single plot of aggregation. Defuzzification is then performed using the gravity center technique and the result of the defuzzification is a crisp value which is shown at the top of the last column. The output of the inference engine can be a value in the range 0–100.

Data from the most recent 5 year (2005–2009) were analyzed using the proposed methodology to determine the criteria-level. The criteria-level of the fuzzy model is converted into implication (if the criteria-level is greater than 50, the implication is assumed to be ‘Good’). The results obtained are shown in Table 5.

The criteria output is used to obtain the appropriate actions for healthcare management. The flowchart used to obtain the

suggested action is shown in Fig. 6. The suggested actions are obtained from the domain knowledge experts.

The algorithm used to get the suggested actions is summarized in the following steps:

1. Input Criteria implication (‘Bad’ or ‘Good’)
2. Check value of Criteria implication.
  - a. If Criteria implication is ‘Good’ then there is no suggested action.
  - b. If Criteria implication is ‘Bad’ then search variables input from fuzzy logic that have value ‘Low’ or ‘High’.
3. Check value for Mortality variable.
  - a. If Mortality is ‘Low’ then there is no suggested action.
  - b. If Mortality is ‘Medium’ then give a suggested action.
  - c. If Mortality is ‘High’ then give a suggested action.
4. Check value for Morbidity variable.
  - a. If Morbidity is ‘Low’ then there is no suggested action.
  - b. If Morbidity is ‘Medium’ then give a suggested action.
  - c. If Morbidity is ‘High’ then give a suggested action.
5. Check value for Fertility variable.
  - a. If Fertility is ‘Low’ then there is no suggested action.
  - b. If Fertility is ‘Medium’ then give a suggested action.
  - c. If Fertility is ‘High’ then give a suggested action.

An example, if the criteria is ‘Bad’ and the Mortality is ‘High’, then the suggested actions are given below:

- Protection of pregnant women from one of the main causes of infant death, namely neonatarum tetanus.
- Injection of vaccine for couples to be married.
- Activate the role of village midwives who provide counseling to pregnant women.

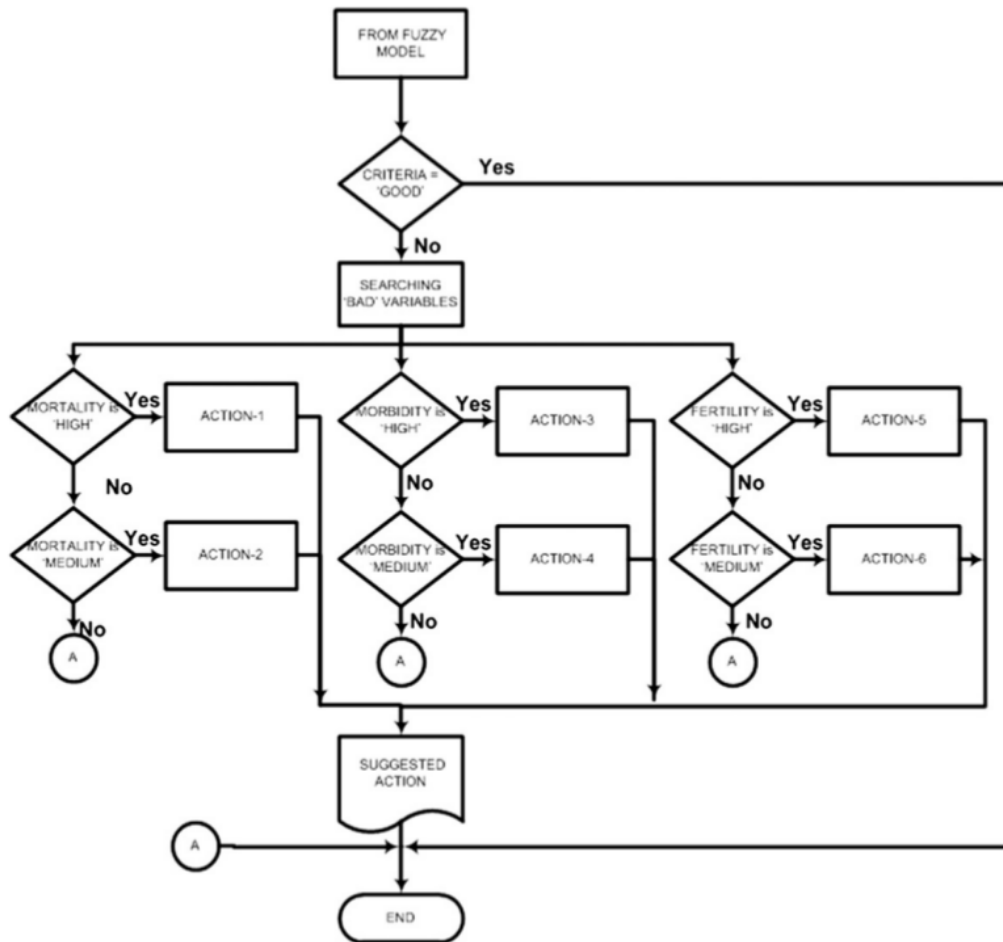

Fig. 6. The flowchart decision logic system for suggested actions.

## 40 6. Conclusion

In this paper, a new dual hybrid model methodology for support of decision making in healthcare management has been presented. Since the healthcare data are in general very complex comprising both linear and nonlinear patterns, using only linear or nonlinear models will not yield good forecasting results. In this paper, a combination of linear regression and neural network models has been employed to get more accurate prediction results. Three types of data in healthcare namely, infant mortality rate, morbidity of tuberculosis and crude birth rate, have been used for conducting the experiments. The results of prediction form the inputs to the Fuzzy model which yields a criteria level that is yes as the basis for an appropriate action plan. The proposed dual hybrid model is used not only for getting more accurate prediction results but also for generating appropriate decisions which will be helpful for the healthcare managers.

## References

- [1] Santoso S. Business forecasting: contemporary business forecasting methods using Minitab and SPSS. Jakarta: Elex Media Komputindo; 2009.
- [2] Makridakis S, Wheelwright SC, McGee VE. Forecasting: methods and applications. Jakarta: Binarupa Aksara; 2009.
- [3] Zhuang Y, Chen L, Wang XS, Lian J. A weighted moving average-based approach for cleaning sensor data. In: 27th international conference on distributed. Computing Systems; 2007. p. 38–45.
- [4] Moghaddas-Tafreshi SM, Farhadi M. Linear regression-based study for temperature sensitivity analysis of Iran electrical load. In: IEEE international conference on industrial technology; 2008. p. 1–7.
- [5] Javier C, Rosario E, Francisco JN, Conejo AJ. ARIMA models to predict next-day electricity prices. IEEE Trans Power Syst 2003;18:1014–20.
- [6] Moradzadehfard M, Motlagh PA, Fathi MR. Comparing neural network and multiple regression models to estimate dividend payout ratio. Middle-East J Sci Res 2011;10(3):302–9.
- [7] Binner JM, Bissoondeal RK, Elger T, Gazely AM, Mullineux AW. A comparison of linear forecasting models and neural networks: an application to Euro inflation and Euro Divisia. Appl Econom 2005;37(6):665–80.
- [8] Maier HR, Dandy GC. Neural network models for forecasting univariate time series. Neural Networks World 1996;6:747–72.
- [9] Jain BA, Nag BN. Performance evaluation of neural network decision models. Manage Inf Syst 1997;14:201–16.
- [10] Niskaa H, Hiltunen T, Karppinenb A, Ruuskanena J, Kolehmainen M. Evolving the neural network model for forecasting air pollution time series. Eng Appl Artif Intell 2004;17:159–67.
- [11] Georgakarakos S, Koutsoubas D, Valavanis V. Time series analysis and forecasting techniques applied on Ioliginid and ommastrephid Landings in Greek waters. Fisheries Res 2006;78:55–71.
- [12] Aminian F, Suarez ED, Aminian M, Walz DT. Forecasting economic data with neural networks. Comput Econ 2006;28:71–88.
- [13] Msiza IS, Nelwamondo FV, Marwala T. Water demand prediction using artificial neural networks and support vector regression. J Comput 2008;3: 1–8.
- [14] Zhang GP. Time series forecasting using a hybrid ARIMA and neural network model. Neurocomputing 2003;50:159–75.

- [15] Thissen U, van Brakel R, de Weijer AP, Melssen WJ, Buydens LMC. Using support vector machines for time series prediction. *Chemom Intell Lab Syst* 2003;69:35–49.
- [16] Thissen U. Using support vector machines for time series prediction and product quality control. Department of Analytical Chemistry, University of Nijmegen. <[www.strath.ac.uk/Other/cpact/presentations/2003/ppts/Thissen.ppt](http://www.strath.ac.uk/Other/cpact/presentations/2003/ppts/Thissen.ppt)> [cited 25.01.12].
- [17] Nugroho AS, Witarto AB, Handoko D. Support vector machine-theory and applications in bioinformatics; 2003. <[www.ilmukomputer.com](http://www.ilmukomputer.com)> [cited 25.01.12].
- [18] Balabin RM, Lomakina EI. Support vector machine regression (LS-SVM) – an alternative to artificial neural networks (ANNs) for the analysis of quantum chemistry data? *Phys Chem Chem Phys* 2011;13:11710–8.
- [19] Wang D, Larder B, Revell A, Montaner J, Harrigan R, De-Wolf F, et al. A comparison of three computational modelling methods for the prediction of virological response to combination HIV therapy. *Artif Intell Med* 2009;47(1):63–74.
- [20] Kim K. Financial time series forecasting using support vector machines. *Neurocomputing* 2003;55:307–19.
- [21] Hietaniemi M, Elsila U, Laurinen P, Roning J. Defect prediction in hot strip rolling using ANN and SVM. In: Proceedings of the 2008 conference on tenth Scandinavian conference on artificial intelligence; 2008. p. 44–51.
- [22] Diaz-Robles LA, Ortega JC, Fu JS, Reed GD, Chow JC, Watson JG, et al. A hybrid ARIMA and artificial neural networks model to forecast particulate matter in urban areas: the case of Temuco, Chile. *Atmos Environ* 2008;42:8331–40.
- [23] Faruk DO. A Hybrid neural network and ARIMA model for water quality time series prediction. *Eng Appl Artif Intell* 2010;23:586–94.
- [24] Chang FJ, Chang YT. Adaptive neuro-fuzzy inference system for prediction of water level in reservoir. *Adv Water Res* 2006;29:1–10.
- [25] Tektas M. Weather forecasting using ANFIS and ARIMA models, a case study for Istanbul. *Environ Res Eng Manage* 2010;1(51):5–10.
- [26] Hernandez SCA, Pedraza MLF, Salcedo POJ. Comparative analysis of time series techniques ARIMA and ANFIS to forecast WiMAX traffic. *Online J Electron Electr Eng* 2010;2(2):223–8.
- [27] Woodside JM. Neuro-fuzzy CBR hybridization: healthcare application. In: IEEE international joint conference. *Neural Networks*; 2008. p. 1814–19.
- [28] Aruna P, Puviarasan N, Palaniappan B. An investigation of neuro-fuzzy systems in psychosomatic disorders. *Expert Syst Appl* 2005;28:673–9.
- [29] Hamdan H, Garibaldi JM. Adaptive Neuro-Fuzzy Inference System (ANFIS) in modelling breast cancer survival. In: IEEE world congress on, computational intelligence; 2010. p. 573–80.
- [30] Koutsoujannis C, Hatzilygeroudis I. Using a neurofuzzy approach in a medical application. In: Apolloni B, et al. (editors), *KES 2007/WIRN 2007, Part II, LNAI 4693*, p. 477–84.
- [31] Petrovic D, Xie Y, Burnham K. Fuzzy decision support system for demand forecasting with a learning mechanism. *Fuzzy Sets Syst* 2006;157:1713–25.
- [32] Bates JHT, Young MP. Applying fuzzy logic to medical decision making in the intensive care unit. *Am J Respir Crit Care Med* 2003;167:948–52.
- [33] Agami N, Saleh M, El-Shishiny H. A fuzzy logic based trend impact analysis method. *Technol Forecasting Soc Change* 2010;77:1051–60.
- [34] Le CT. *Introductory biostatistics*. New Jersey: John Wiley & Sons; 2003.
- [35] DeCoster J. *Notes on applied linear regression*. Amsterdam: Department of Social Psychology, Free University Amsterdam; 2003.
- [36] Suhartono. *Feedforward neural networks for time series modeling*. Yogyakarta: Gajah Mada University; 2008.
- [37] Dewi SK. *Neuro-fuzzy: integration of fuzzy system and neural network*. Yogyakarta: Graha Ilmu; 2006.
- [38] Diaz-Robles LA, Ortega JC, Fu JS, Reed GD, Chow JC, Watson JG, et al. A hybrid ARIMA and artificial neural networks model to forecast particulate matter in urban areas: the case of Temuco, Chile. *Atmos Environ* 2008;42:8331–40.
- [39] Rojas I, Valenzuela O, Rojas F, Guillen A, Herrera LJ, Pomares H, et al. Soft-computing techniques and ARMA model for time series prediction. *Neurocomputing* 2008;71:519–37.
- [40] Galindo J, Urrutia A, Piattini M. *Fuzzy databases: modeling, design and implementation*. London: Idea Group Inc.; 2006.
- [41] World Health Organization. *Global tuberculosis control: epidemiology, strategy, financing*. Geneva: WHO Press; 2009.
- [42] Ministry of Health Republic of Indonesia. *Pengendalian TB di indonesia mendekati target MDG*; 2010. <<http://www.depkes.go.id>> [cited 25.01.10].
- [43] Barrientos M. *Tuberculosis morbidity in Indonesia*; 2010. <<http://www.indexmundi.com>> [cited 29.01.10].
- [44] Campos I, Islas M, González E, Ponce P, Ramírez G. Use of fuzzy logic for modeling the growth of Fe<sub>2</sub>B boride layers during boronizing. *Surf Coat Technol* 2006;201:2717–23.

# A dual hybrid forecasting model for support of decision making

---

## ORIGINALITY REPORT

---

15%

SIMILARITY INDEX

7%

INTERNET SOURCES

10%

PUBLICATIONS

8%

STUDENT PAPERS

---

## PRIMARY SOURCES

---

- |   |   |     |
|---|---|-----|
| 1 | <a href="http://www.mul2.polito.it">www.mul2.polito.it</a><br>Internet Source   | 1%  |
| 2 | Ligeng Zou, Zuping Zhang, Jun Long. "An efficient algorithm for increasing the granularity levels of attributes in formal concept analysis", <i>Expert Systems with Applications</i> , 2016<br>Publication                        | 1%  |
| 3 | Lecture Notes in Computer Science, 2007.<br>Publication   | 1%  |
| 4 | <a href="http://cache.oalib.com">cache.oalib.com</a><br>Internet Source   | 1%  |
| 5 | Salim Heddam. "Modeling hourly dissolved oxygen concentration (DO) using two different adaptive neuro-fuzzy inference systems (ANFIS): a comparative study", <i>Environmental Monitoring and Assessment</i> , 2013<br>Publication | 1%  |
| 6 | Ion Iancu. "Chapter 8 A Mamdani Type Fuzzy Logic Controller", <i>IntechOpen</i> , 2012<br>Publication   | <1% |
-

7	Submitted to Loughborough University Student Paper	<1%
8	technav.ieee.org Internet Source	<1%
9	www.uni-magdeburg.de Internet Source	<1%
10	Ali, A.. "A visual probe localization and calibration system for cost-effective computer-aided 3D ultrasound", Computers in Biology and Medicine, 200708 Publication	<1%
11	Bangzhu Zhu, Julien Chevallier. "Pricing and Forecasting Carbon Markets", Springer Science and Business Media LLC, 2017 Publication	<1%
12	Submitted to The University of Manchester Student Paper	<1%
13	Submitted to Indiana University Student Paper	<1%
14	Zhi-Peng LI, Hong YU, Yun-Cai LIU, Fu-Qiang LIU. "An Improved Adaptive Exponential Smoothing Model for Short-term Travel Time Forecasting of Urban Arterial Street", Acta Automatica Sinica, 2008 Publication	<1%

15

Javad Abdi, Behzad Moshiri, Baher Abdulhai, Ali Khaki Sedigh. "Short-term traffic flow forecasting: parametric and nonparametric approaches via emotional temporal difference learning", Neural Computing and Applications, 2012

Publication

&lt;1%

16

Submitted to Institute of Graduate Studies, UiTM

Student Paper

&lt;1%

17

Submitted to Cardiff University

Student Paper

&lt;1%

18

[pdfs.semanticscholar.org](https://pdfs.semanticscholar.org)

Internet Source

&lt;1%

19

[www.ijert.org](http://www.ijert.org)

Internet Source

&lt;1%

20

Ruiz-Aguilar, J.J., I.J. Turias, and M.J. Jiménez-Come. "Hybrid approaches based on SARIMA and artificial neural networks for inspection time series forecasting", Transportation Research Part E Logistics and Transportation Review, 2014.

Publication

&lt;1%

21

[cadentgas.com](http://cadentgas.com)

Internet Source

&lt;1%

22

Submitted to Universiti Sultan Zainal Abidin

Student Paper

&lt;1%

---

23 Roman M. Balabin, Ekaterina I. Lomakina. "Support vector machine regression (LS-SVM)—an alternative to artificial neural networks (ANNs) for the analysis of quantum chemistry data?", Physical Chemistry Chemical Physics, 2011  
Publication <1%

---

24 [internationalscienceindex.org](http://internationalscienceindex.org)  
Internet Source <1%

---

25 Jinhua Li, Qun Dai, Rui Ye. "A novel double incremental learning algorithm for time series prediction", Neural Computing and Applications, 2018  
Publication <1%

---

26 Submitted to University of Ulster  
Student Paper <1%

---

27 Lu, W.-Z.. "Potential assessment of a neural network model with PCA/RBF approach for forecasting pollutant trends in Mong Kok urban air, Hong Kong", Environmental Research, 200409  
Publication <1%

---

28 Submitted to Universiti Teknikal Malaysia Melaka  
Student Paper <1%

---

29	Internet Source	<1%
30	download.atlantis-press.com Internet Source	<1%
31	armadaassets.com.au Internet Source	<1%
32	eprints.utm.my Internet Source	<1%
33	Submitted to Cranfield University Student Paper	<1%
34	"Advances in Computational Intelligence", Springer Science and Business Media LLC, 2019 Publication	<1%
35	publichealth.jmir.org Internet Source	<1%
36	wwwconference.org Internet Source	<1%
37	Lowry, G.. "Seasonal autoregressive modelling of water and fuel consumptions in buildings", Applied Energy, 200705 Publication	<1%
38	Jun-dong Wang. "River Water Turbidity Forecasting Based on Phase Space Reconstruction and Support Vector	<1%



Regression", 2010 International Conference on Intelligent Computation Technology and Automation, 05/2010

Publication

---

39

Roselina Sallehuddin, Siti Mariyam Hj. Shamsuddin. "HYBRID GREY RELATIONAL ARTIFICIAL NEURAL NETWORK AND AUTO REGRESSIVE INTEGRATED MOVING AVERAGE MODEL FOR FORECASTING TIME-SERIES DATA", Applied Artificial Intelligence, 2009

Publication

---

<1%

40

[bdataanalytics.biomedcentral.com](http://bdataanalytics.biomedcentral.com)

Internet Source

---

<1%

41

[www.ncbi.nlm.nih.gov](http://www.ncbi.nlm.nih.gov)

Internet Source

---

<1%

42

Subhashini Narayan, E. Sathiyamoorthy. "A novel recommender system based on FFT with machine learning for predicting and identifying heart diseases", Neural Computing and Applications, 2018

Publication

---

<1%

43

[mdpi.com](http://mdpi.com)

Internet Source

---

<1%

44

Submitted to Jawaharlal Nehru Technological University Anantapur

Student Paper

<1%

---

45

[hdl.handle.net](http://hdl.handle.net)

Internet Source

<1%

---

46

Tshilidzi Marwala. "Finite-element-model Updating Using Computational Intelligence Techniques", Springer Science and Business Media LLC, 2010

Publication

<1%

---

47

Submitted to University of Bath

Student Paper

<1%

---

48

Yu, L.. "A novel nonlinear ensemble forecasting model incorporating GLAR and ANN for foreign exchange rates", Computers and Operations Research, 200510

Publication

<1%

---

49

R. Samsudin. "A hybrid least squares support vector machines and GMDH approach for river flow forecasting", Hydrology and Earth System Sciences Discussions, 06/23/2010

Publication

<1%

---

50

Submitted to University College London

Student Paper

<1%

---

51

Logeswaran, R.. "Stone detection in MRCP images using controlled region growing", Computers in Biology and Medicine, 200708

Publication

<1%

---

52

Submitted to University of Portsmouth

Student Paper

&lt;1%

53

Submitted to Asian Institute of Technology

Student Paper

&lt;1%

54

Khashei, Mehdi, and Mehdi Bijari. "Hybridization of the probabilistic neural networks with feed-forward neural networks for forecasting", Engineering Applications of Artificial Intelligence, 2012.

Publication

&lt;1%

55

Submitted to Universiti Teknologi Petronas

Student Paper

&lt;1%

56

Mergani A. Khairalla, Xu Ning, Nashat T. AL-Jallad, Musaab O. El-Faroug. "Short-Term Forecasting for Energy Consumption through Stacking Heterogeneous Ensemble Learning Model", Energies, 2018

Publication

&lt;1%

57

Submitted to National College of Ireland

Student Paper

&lt;1%

58

Razana Alwee, Siti Mariyam Hj Shamsuddin, Roselina Sallehuddin. "Hybrid Support Vector Regression and Autoregressive Integrated Moving Average Models Improved by Particle Swarm Optimization for Property Crime Rates Forecasting with Economic Indicators", The

&lt;1%

# Scientific World Journal, 2013

Publication

---

---

Exclude quotes      Off

Exclude matches      < 5 words

Exclude bibliography      On